

Features

- Peak pulse power 600 W (10/1000 μ s)
- Stand off voltage 3.3 V
- Unidirectional type
- Low clamping factor
- Fast response time
- JEDEC registered package outline

Description

The SMLVT3V3 is a Transil diode designed specifically to protect sensitive 3.3 V equipment against transient overvoltages.

Transil diodes provide high overvoltage protection by clamping action. Their instantaneous response to transient overvoltages make them particularly suited to protect voltage sensitive devices such as MOS technology and low voltage supplied ICs

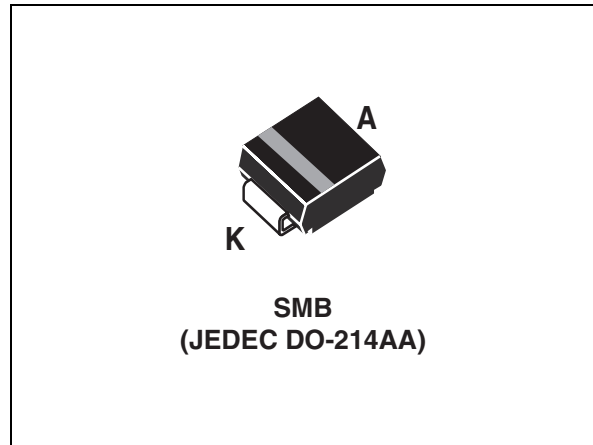

Order code

Part number	Marking
SMLVT3V3	CD

Table 1. Absolute maximum ratings ($T_{amb} = 25^{\circ} C$)

Symbol	Parameter		Value	Unit
P_{PP}	Peak pulse power dissipation ⁽¹⁾	$T_j \text{ initial} = T_{amb}$	600	W
P	Power dissipation on infinite heatsink	$T_{amb} = 50^{\circ} C$	6	W
I_{FSM}	Non repetitive surge peak forward current for unidirectional types	$t_p = 10 \text{ ms}$ $T_j \text{ initial} = T_{amb}$	100	A
T_{stg}	Storage temperature range		-65 to +175	$^{\circ} C$
T_j	Maximum junction temperature		+175	$^{\circ} C$
T_L	Maximum lead temperature for soldering during 10 s.		260	$^{\circ} C$

1. For a surge greater than the maximum values, the diode will fail in short-circuit.

TM: Transil is a trademark of STMicroelectronics

1 Characteristics

Table 2. Thermal resistances

Symbol	Parameter	Value	Unit
$R_{th(j-l)}$	Junction to leads	20	° C/W
$R_{th(j-a)}$	Junction to ambient on printed circuit on recommended pad layout	100	° C/W

Symbol	Parameter
V_{RM}	Stand-off voltage
V_{BR}	Breakdown voltage
V_{CL}	Clamping voltage
I_{RM}	Leakage current @ VRM
I_{PP}	Peak pulse current
αT	Voltage temperature coefficient
V_F	Forward voltage drop
R_D	Dynamic impedance

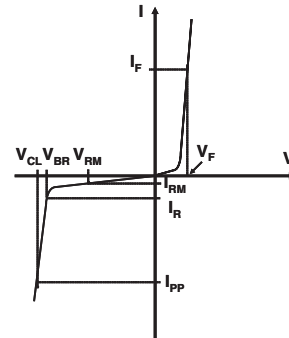

Type	$I_{RM} @ V_{RM}$		$V_{BR} @ I_R^{(1)}$		$V_{CL} @ I_{PP} 10/1000 \mu s$		$V_{CL} @ I_{PP} 8/20 \mu s$		$\alpha T^{(2)}$	$C^{(3)}$
	Max		Min		Max		Max		Max	Typ.
	μA	V	V	mA	V	A	V	A	10-4/° C	pF
SMLVT3V3	200	3.3	4.1	1	7.3	50	10.3	200	-5.3	5200

1. Pulse test : $t_p < 50 \text{ ms}$
2. $V_{BR} = \alpha T \times (T_{amb} - 25) \times V_{BR}(25^\circ C)$
3. $V_R = 0 \text{ V}$, $F = 1 \text{ MHz}$

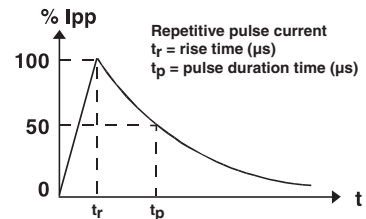

Figure 1. Peak pulse power dissipation versus initial junction temperature (printed circuit board)

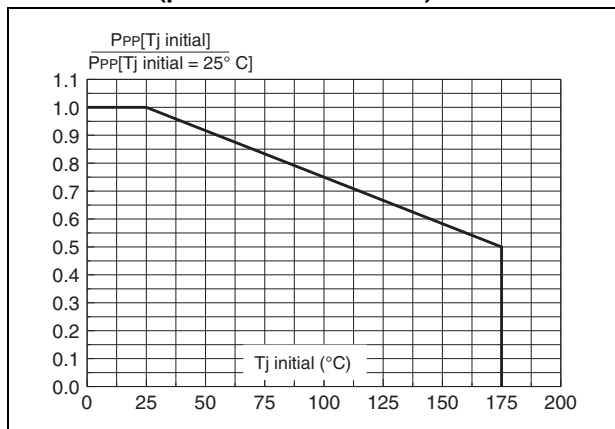

Figure 2. Peak pulse power versus exponential pulse duration

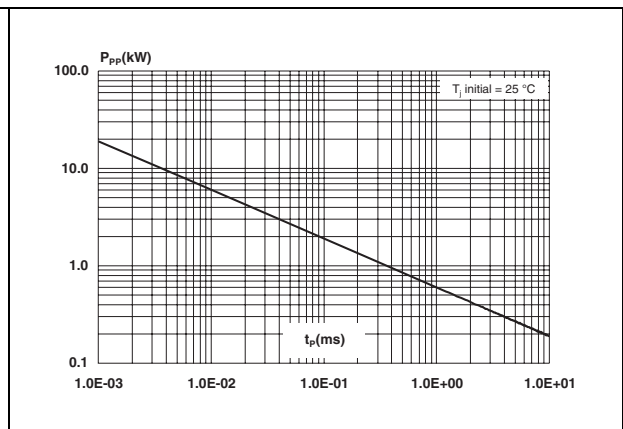

Figure 3. Clamping voltage versus peak pulse current (exponential waveform, maximum values)

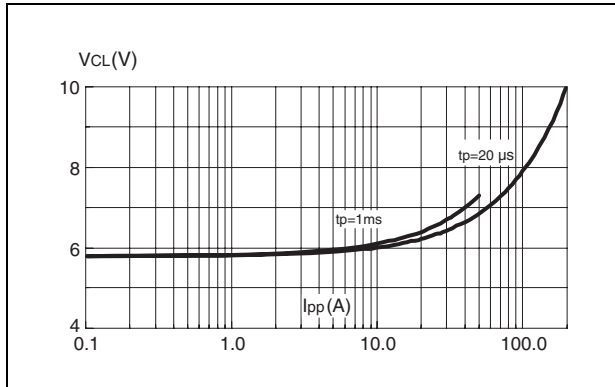

Figure 4. Junction capacitance versus reverse applied voltage (typical values)

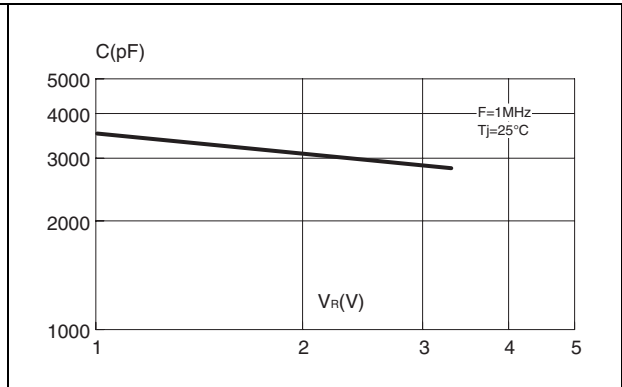

Figure 5. Peak forward voltage drop versus peak forward current (typical values)

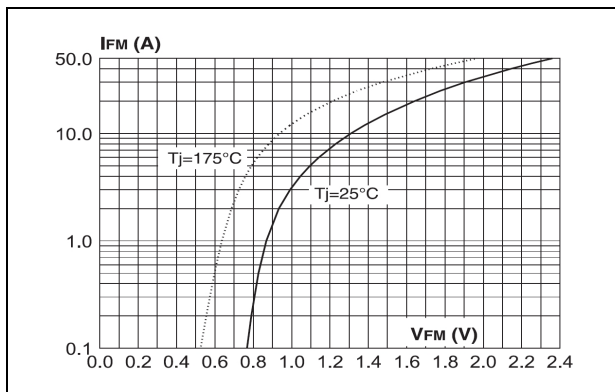

Figure 6. Transient thermal impedance, junction to ambient, versus pulse duration (PCB - FR4, with recommended pad layout)

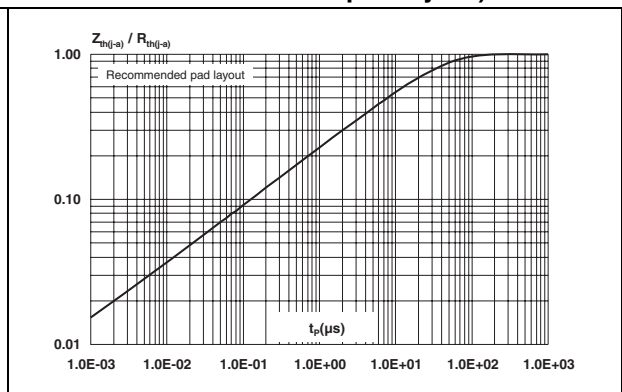
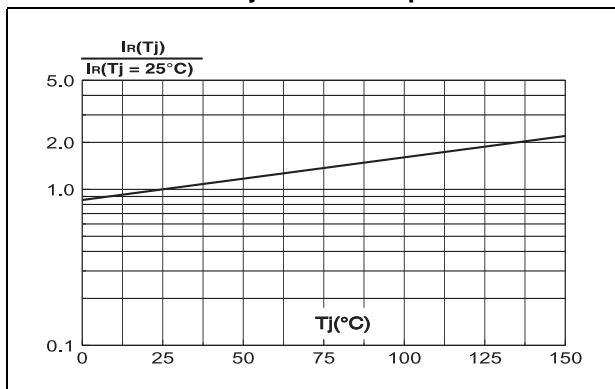
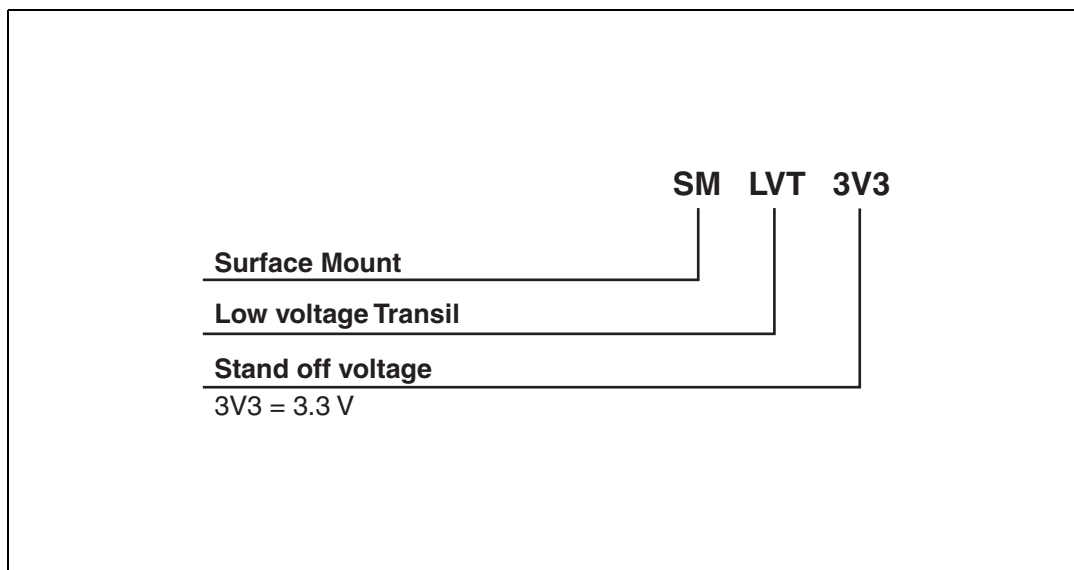

Figure 7. Relative variation of leakage current versus junction temperature



2 Order information scheme



3 Package information

- Case: JEDEC DO-214AA molded plastic over Planar junction
- Epoxy is rated UL94V-0
- RoHS compliant package

Table 3. SMB Dimensions

Ref.	Dimensions			
	Millimeters		Inches	
	Min.	Max.	Min.	Max.
A1	1.90	2.45	0.075	0.096
A2	0.05	0.20	0.002	0.008
b	1.95	2.20	0.077	0.087
c	0.15	0.40	0.006	0.016
E	5.10	5.60	0.201	0.220
E1	4.05	4.60	0.159	0.181
D	3.30	3.95	0.130	0.156
L	0.75	1.50	0.030	0.059

Figure 8. Footprint dimensions (millimeter)

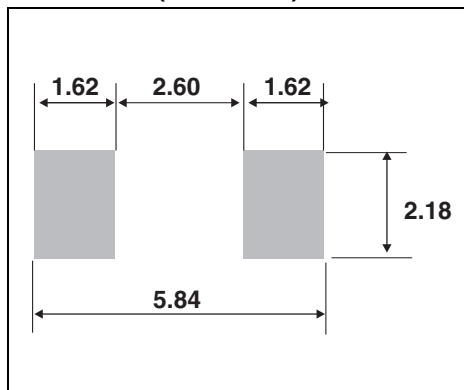
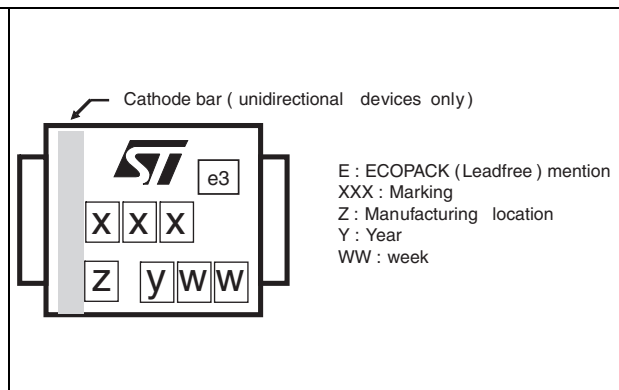

Figure 9. Marking layout



In order to meet environmental requirements, ST offers these devices in ECOPACK® packages. These packages have a Lead-free second level interconnect . The category of second level interconnect is marked on the package and on the inner box label, in compliance with JEDEC Standard JESD97. The maximum ratings related to soldering conditions are also marked on the inner box label. ECOPACK is an ST trademark. ECOPACK specifications are available at: www.st.com.

4 Ordering information

Part number	Marking	Package	Weight	Base qty	Delivery mode
SMLVT3V3	CD	SMB	0.12 g	2500	Tape and reel

5 Revision history

Table 4. Document revision history

Date	Revision	Changes
Aug-2001	2	Previous issue
25-Apr-2007	3	Reformatted to current standards. Added cathode bar marker in cover page graphics and Figure 9 .

Please Read Carefully:

Information in this document is provided solely in connection with ST products. STMicroelectronics NV and its subsidiaries ("ST") reserve the right to make changes, corrections, modifications or improvements, to this document, and the products and services described herein at any time, without notice.

All ST products are sold pursuant to ST's terms and conditions of sale.

Purchasers are solely responsible for the choice, selection and use of the ST products and services described herein, and ST assumes no liability whatsoever relating to the choice, selection or use of the ST products and services described herein.

No license, express or implied, by estoppel or otherwise, to any intellectual property rights is granted under this document. If any part of this document refers to any third party products or services it shall not be deemed a license grant by ST for the use of such third party products or services, or any intellectual property contained therein or considered as a warranty covering the use in any manner whatsoever of such third party products or services or any intellectual property contained therein.

UNLESS OTHERWISE SET FORTH IN ST'S TERMS AND CONDITIONS OF SALE ST DISCLAIMS ANY EXPRESS OR IMPLIED WARRANTY WITH RESPECT TO THE USE AND/OR SALE OF ST PRODUCTS INCLUDING WITHOUT LIMITATION IMPLIED WARRANTIES OF MERCHANTABILITY, FITNESS FOR A PARTICULAR PURPOSE (AND THEIR EQUIVALENTS UNDER THE LAWS OF ANY JURISDICTION), OR INFRINGEMENT OF ANY PATENT, COPYRIGHT OR OTHER INTELLECTUAL PROPERTY RIGHT.

UNLESS EXPRESSLY APPROVED IN WRITING BY AN AUTHORIZED ST REPRESENTATIVE, ST PRODUCTS ARE NOT RECOMMENDED, AUTHORIZED OR WARRANTED FOR USE IN MILITARY, AIR CRAFT, SPACE, LIFE SAVING, OR LIFE SUSTAINING APPLICATIONS, NOR IN PRODUCTS OR SYSTEMS WHERE FAILURE OR MALFUNCTION MAY RESULT IN PERSONAL INJURY, DEATH, OR SEVERE PROPERTY OR ENVIRONMENTAL DAMAGE. ST PRODUCTS WHICH ARE NOT SPECIFIED AS "AUTOMOTIVE GRADE" MAY ONLY BE USED IN AUTOMOTIVE APPLICATIONS AT USER'S OWN RISK.

Resale of ST products with provisions different from the statements and/or technical features set forth in this document shall immediately void any warranty granted by ST for the ST product or service described herein and shall not create or extend in any manner whatsoever, any liability of ST.

ST and the ST logo are trademarks or registered trademarks of ST in various countries.

Information in this document supersedes and replaces all information previously supplied.

The ST logo is a registered trademark of STMicroelectronics. All other names are the property of their respective owners.

© 2007 STMicroelectronics - All rights reserved

STMicroelectronics group of companies

Australia - Belgium - Brazil - Canada - China - Czech Republic - Finland - France - Germany - Hong Kong - India - Israel - Italy - Japan - Malaysia - Malta - Morocco - Singapore - Spain - Sweden - Switzerland - United Kingdom - United States of America

www.st.com